

Pump & Motor Division

PGP/PGM 600 Series
Service Manual



ENGINEERING YOUR SUCCESS.



WARNING – User Responsibility

FAILURE OR IMPROPER SELECTION OR IMPROPER USE OF THE PRODUCTS AND/OR SYSTEMS DESCRIBED HEREIN OR RELATED ITEMS CAN CAUSE DEATH, PERSONAL INJURY AND PROPERTY DAMAGE.

This document and other information from Parker Hannifin Corporation, its subsidiaries and authorized distributors provide product and/or system options for further investigation by users having technical expertise. It is important that you analyze all aspects of your application and review the information concerning the product or system in the current product catalog. Due to the variety of operating conditions and applications for these products or systems, the user, through its own analysis and testing, is solely responsible for making the products and systems and assuring that all performance, safety and warning requirements of the application are met.

The products described herein, including without limitation, product features, specifications, designs, availability and pricing, are subject to change by Parker Hannifin Corporation and its subsidiaries at any time without notice.

Offer of Sale

The items described in this document are hereby offered for sale by Parker Hannifin Corporation, its subsidiaries or its authorized distributors. This offer and its acceptance are governed by the provisions stated in the "Offer of Sale".

© Copyright 2020, Parker Hannifin Corporation, All Rights Reserved



WARNING: This product can expose you to chemicals including lead or DEHP which are known to the state of California to cause cancer, birth defects, and other reproductive harm. www.p65warnings.ca.gov



Table of Contents

General Information	1-4
Single Pump	1
Use Genuine Parker Replacement Parts	2
Tool List	3-4
Exploded View	5
Bill of Materials	6
Disassembly Instructions	7-10
Assembly Instructions	11-17
Guidelines of Acceptable Wear	18-19
Fluid Recommendations	20-22
Start-up Procedure / Test Procedure	23
Offer of Sale	27-28

 **WARNING:** This product can expose you to chemicals including lead or DEHP which are known to the state of California to cause cancer, birth defects, and other reproductive harm. www.p65warnings.ca.gov



Single Pump

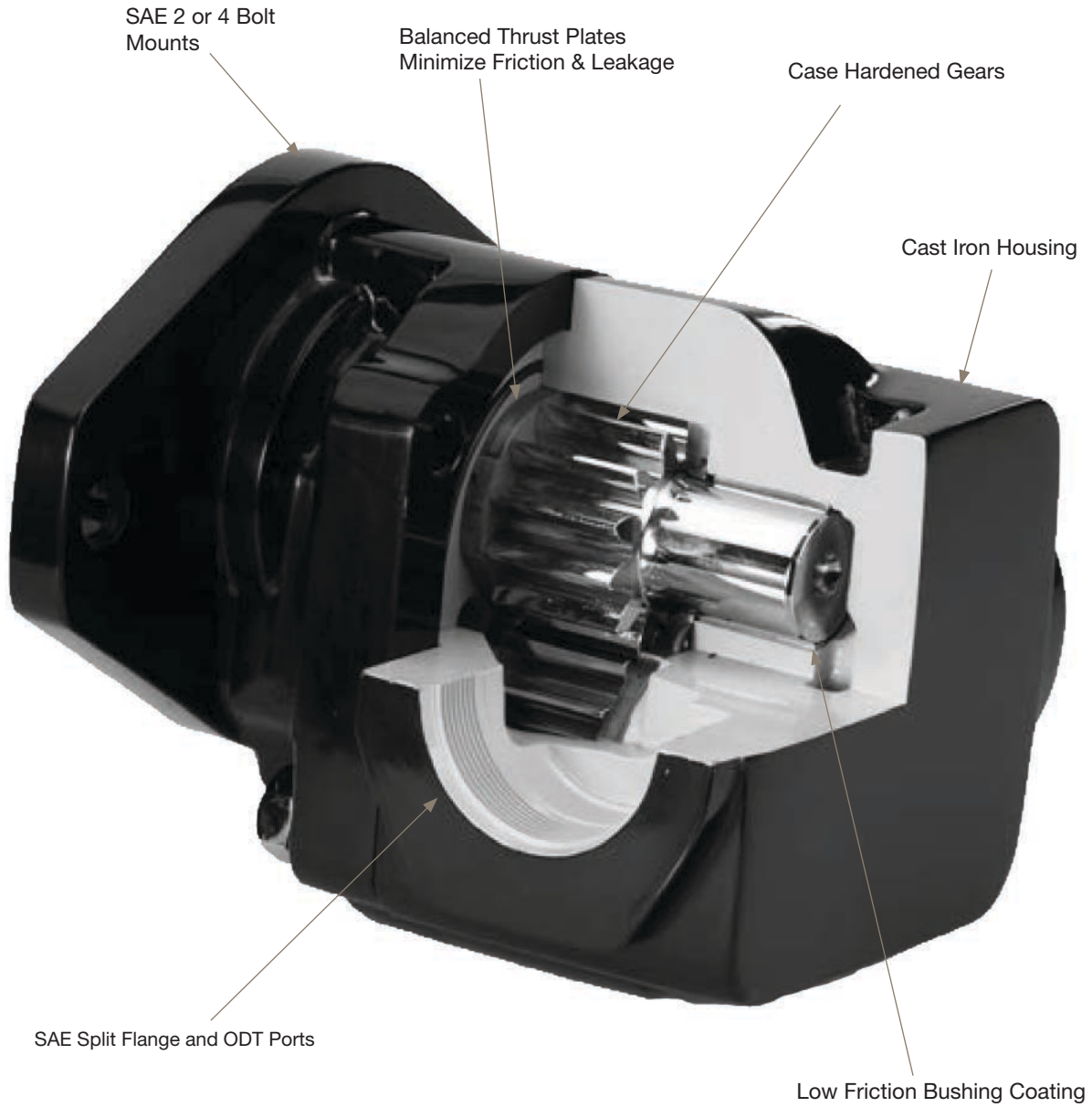

⚠ WARNING: This product can expose you to chemicals including lead or DEHP which are known to the state of California to cause cancer, birth defects, and other reproductive harm. www.p65warnings.ca.gov



Use Genuine Parker Replacement Parts

These service instructions will familiarize you with Parker's single and multiple pumps, their component parts, the relative position of each part proper methods for assembly or disassembly of the units

To facilitate the repair of these units, and before any work is done, we suggest that you first read all of the steps used in disassembly and assembly.

Dirt is the enemy of any hydraulic system. The first requirement of good maintenance of hydraulic equipment is cleanliness. **MAKE SURE YOU DISASSEMBLE AND ASSEMBLE YOUR HYDRAULIC EQUIPMENT IN A CLEAN AREA.**

The pictures show Model PGP620. Notes in the text cover variations between this unit and the other models.

It is important to airblast all parts and wipe them with a clean, lintless cloth before assembly.

USE CAUTION IN GRIPPING ALL PARTS IN THE VISE TO AVOID DAMAGING MACHINED SURFACES

A pump must be driven in the direction of rotation for which it was built; otherwise, the pressure will blow the shaft seal. Check the exploded view and notes at right for proper direction of rotation.

Parker's Replacement Parts

Parker's replacement parts are of original equipment standards. For assured quality of material and workmanship, and for compatibility in assembly, **USE ONLY GENUINE PARTS.**

Check all replacement parts before installing them to be certain that they were not damaged in shipment.

 **WARNING:** This product can expose you to chemicals including lead or DEHP which are known to the state of California to cause cancer, birth defects, and other reproductive harm. www.p65warnings.ca.gov



Tool List	
Arbor press	Bearing puller (Owatonna Tool Co. M D - 956 or equivalent)
Awl	Deburring tool (an old file with cutting teeth ground off)
1-1/2" Dia. steel ball	No. 3 non-hardening sealant or equivalent
Clean, lintless cloths	Permatex Aviation Form-A-Gasket™
Machinist's hammer	Medium grit carborundurn stone
Soft hammer	Scale (1/32" or 1/64" graduations)
Oil and grease	Vise with 6" minimum opening
Snap ring pliers	Seal removal tool (See A)
Prick punch	Bushing installation tool (See B)
Small screw driver	Special steel sleeve (See C)
Torque wrench	

Bar for lip seal installation:	
PGP/PGM610 use 1-5/8" dia. x 2" bar (22mm x 50mm)	PGP/PGM640 use 2-1/2" dia. x 2" bar (32mm x 50mm)
PGP/PGM620 use 1-3/4" dia. x 2" bar (24mm x 50mm)	

A Seal Removal Tool
 Easily made from an old screw driver. Heat the tip and bend as shown. Grind the tip to fit the notch behind the shaft seal.

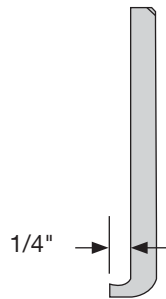

WARNING: This product can expose you to chemicals including lead or DEHP which are known to the state of California to cause cancer, birth defects, and other reproductive harm. www.p65warnings.ca.gov

B Bushing Installation Tool: A.I.S.I 8620 Bearing Quality Steel Heat Treated

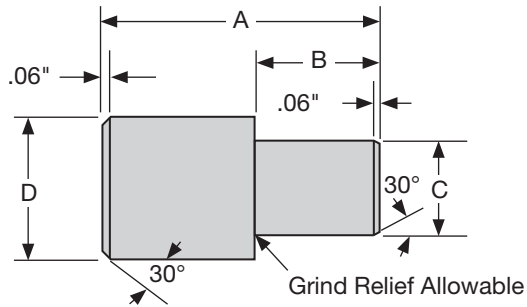

Pump/Motor	A	B	C Dia.	D Dia.
PGP/PGM610	3.000"	.854"	.854" $\begin{smallmatrix} +.000" \\ -.002" \end{smallmatrix}$	1.250
PGP/PGM620	3.000"	1.092"	1.172" $\begin{smallmatrix} +.000" \\ -.002" \end{smallmatrix}$	1.250
PGP/PGM640	3.000"	1.280"	1.280" $\begin{smallmatrix} +.000" \\ -.002" \end{smallmatrix}$	1.625

C Special Steel Sleeve

The special steel sleeve is used to insert the drive shaft through the lip seal without damage and can be made from bar stock:

PGP/PGM610: Use a 1" dia. x 3-1/4" bar

PGP/PGM620: Use a 1-3/8" dia. x 4-5/8" bar

PGP/PGM640: Use a 1" dia. x 4-5/8" bar

The drawing and chart give details for making this special tool.

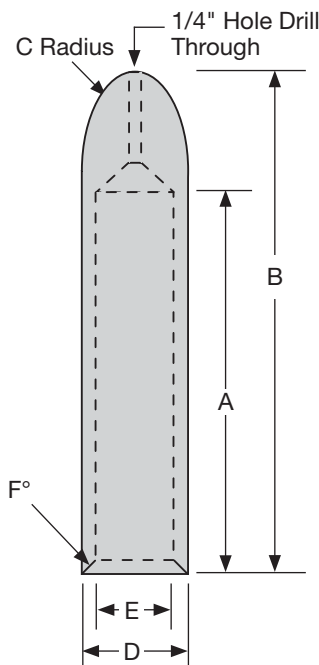

Pump/Motor	A	B	C Radius	D Dia.	E Dia.	F° Chamfer
PGP/PGM610	1-7/8"	3"	9/16"	.870" $\begin{smallmatrix} +.000" \\ -.002" \end{smallmatrix}$.610" $\begin{smallmatrix} +.000" \\ -.002" \end{smallmatrix}$.015" x 60°
PGP/PGM620	3-9/64"	4-21/64"	9/16"	.925" $\begin{smallmatrix} +.000" \\ -.002" \end{smallmatrix}$.881" $\begin{smallmatrix} +.000" \\ -.002" \end{smallmatrix}$.015" x 60°
PGP/PGM640	3-3/8"	4-1/2"	9/16"	1.290" $\begin{smallmatrix} +.000" \\ -.002" \end{smallmatrix}$	1.250" $\begin{smallmatrix} +.000" \\ -.002" \end{smallmatrix}$.015" x 60°
PGP/PGM620 - Mylar Sleeve Part #8682-133-00G						

WARNING: This product can expose you to chemicals including lead or DEHP which are known to the state of California to cause cancer, birth defects, and other reproductive harm. www.p65warnings.ca.gov

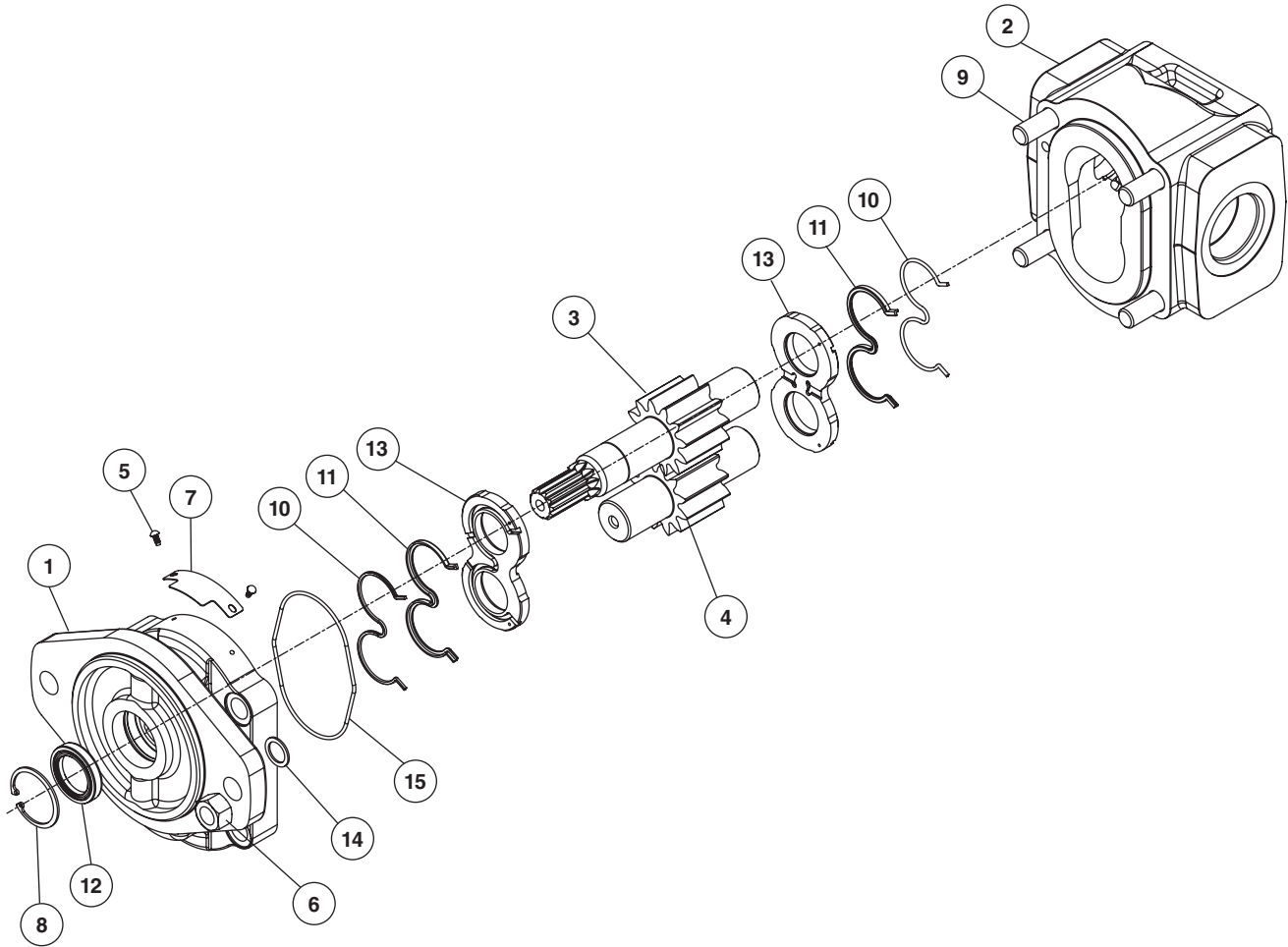

WARNING: This product can expose you to chemicals including lead or DEHP which are known to the state of California to cause cancer, birth defects, and other reproductive harm. www.p65warnings.ca.gov



ITEM	DESCRIPTION	QUANTITY
1	Shaft End Cover, Flange	1
2	Gear Housing, Body	1
3	Gear Shaft, Drive Gear	1
4	Driven Gear, Idler Gear	1
5	Drive Screw	2
6	Hex Nut	4
7	Name Plate	1
8	Snap Ring	1
9	Stud	4
10	Pump Seal Element	2
11	Pump Seal Energ	2
12	Lip Seal	1
13	Balance Plate	2
14	Washer	4
15	Section Seal	1

 **WARNING:** This product can expose you to chemicals including lead or DEHP which are known to the state of California to cause cancer, birth defects, and other reproductive harm. www.p65warnings.ca.gov



Start Disassembly

CAUTION:

1. If prying off sections becomes necessary, take extreme care not to mar or damage machined surfaces. Excessive force while prying can result in misalignment and seriously damage parts.
2. If parts are difficult to fit during assembly, tap gently with a soft hammer. (Never use an iron hammer.)
3. Gears are closely matched, therefore they must be kept together as sets, avoid touching gear journals when removed from a unit. Handle with care to avoid damage to the journals or teeth.
4. Never hammer bushings into bores. Use an arbor press.

- 1) Place the pump in a vise with the drive gear pointing up (**Fig. 1**). Match-mark all sections.

Be sure to align these marks when reassembling.

DO NOT GRIP ON OR NEAR ANY MACHINED SURFACES DURING ASSEMBLY OR DISASSEMBLY.



Figure 1

- 2) Remove four bolts and cap screws on single units or the 4 hex nuts, studs and washers of multiple units (**Fig. 2**).

Use a wrench to remove the 4 capscrews on single units or the 4 hex nuts, studs and washers of multiple units. The back bolts might need to be loosened and the shaft end cover slightly lifted to reach the back nuts all the way removed.



Figure 2

- 3) Place a seal guide over the seal before removing the shaft end cover (**Fig. 3**). This step will help avoid damaging the seal.



Figure 3

 **WARNING:** This product can expose you to chemicals including lead or DEHP which are known to the state of California to cause cancer, birth defects, and other reproductive harm. www.p65warnings.ca.gov

- 4) Lift off the shaft end cover. (**Fig. 4**). If prying with screw driver is necessary, be careful not to damage the machined surfaces.

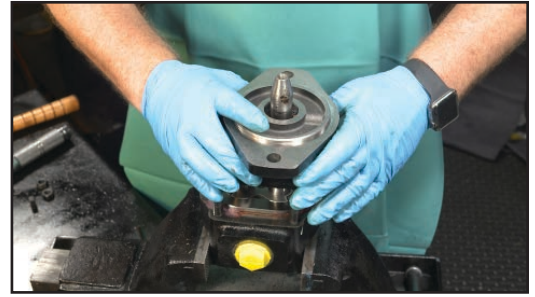

Figure 4

- 5) Remove section seal if didn't come off with the shaft end cover (**Fig. 5**).
Replace with new seal. Install snugly back into bottom of shaft end cover for re-assembly.
Contact an authorized Parker Service Center to determine and order the proper seal kit for your pump.

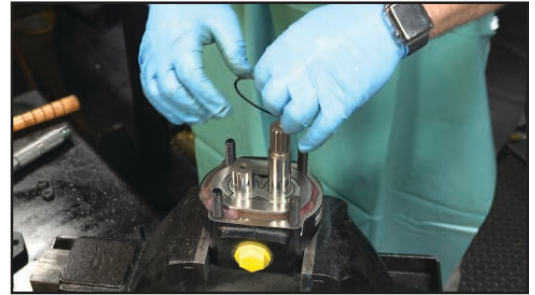

Figure 5

- 6) Remove the thrust plate (**Fig. 6**). Examine and replace if necessary. See Wear Guide ([pages 18-19](#)).
Below are some examples of damaged plates (**Fig. 6a, 6b, 6c, 6d**).



Figure 6



Figure 6a

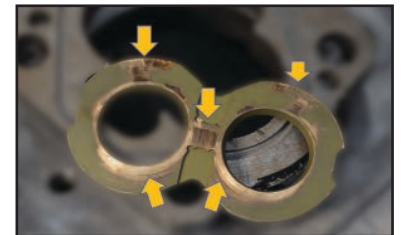



Figure 6b



Figure 6c



Figure 6d

 **WARNING:** This product can expose you to chemicals including lead or DEHP which are known to the state of California to cause cancer, birth defects, and other reproductive harm. www.p65warnings.ca.gov

- 7) Place match marks on gears before removing (Fig. 7).
This will serve as a reference when reassembling the motor.



Figure 7

- 8) Carefully remove drive gear first (Fig. 8).
Avoid tapping the gear teeth together or against other hardened surfaces.

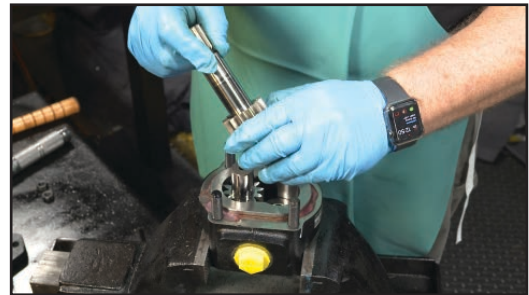

Figure 8

- 9) Next, remove the idler gear while holding down the bottom thrust plate (Fig. 9).
Keep these gears together because they are a matched set.
Examine each for wear and replace if necessary. (See Wear Guide [pages 18-19](#).)

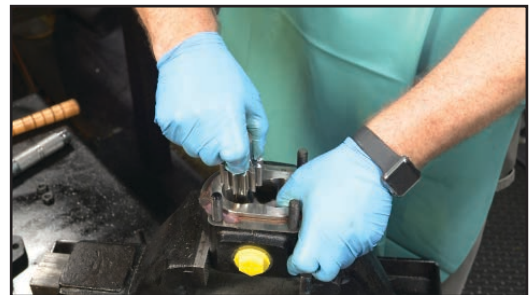

Figure 9

- 10) Carefully remove the thrust plate from the bottom of body (Fig. 10). Examine and replace if necessary. (See Wear Guide [pages 18-19](#).)



Figure 10

WARNING: This product can expose you to chemicals including lead or DEHP which are known to the state of California to cause cancer, birth defects, and other reproductive harm. www.p65warnings.ca.gov

- 11) Remove the snap ring (Fig. 11).**
Snap ring is located in front of the shaft seal ring.



Figure 11

- 12) Remove the lip seal (Fig. 12).**
Be careful not to damage seal bore in pump body.
See tool list on [page 3](#) for prying device.



Figure 12

- 13) Clean all faces of the body and mounting flange from sealant and dirt (Fig. 13).**



Figure 13

 **WARNING:** This product can expose you to chemicals including lead or DEHP which are known to the state of California to cause cancer, birth defects, and other reproductive harm. www.p65warnings.ca.gov

Start Assembly

- 1) Before start, clean all machined surfaces and make sure are free of debris.
- 2) Prep new lip seal for replacement (**Fig. 1**).

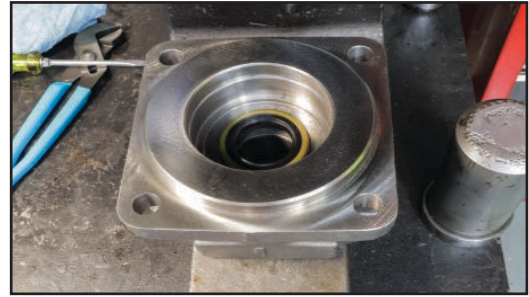

Figure 1

- 3) Grease new lip seal (**Fig. 2**). Coat the outer edge of the lip seal and its recess with non-hardening sealant or equivalent before replacing.



Figure 2

- 4) Replace lip seal (**Fig. 3 & 4**). With the metal side of the lip seal up, press it into the mounting flange side of the shaft end cover with an arbor press and bar (see Tool List on [page 3](#)). Be careful not to damage the lip of the seal.

Press in until flush with the recess. Wipe off excess sealant.



Figure 3

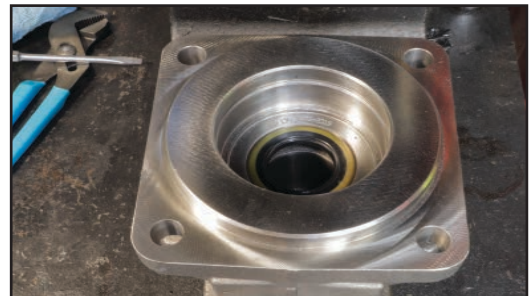

Figure 4

WARNING: This product can expose you to chemicals including lead or DEHP which are known to the state of California to cause cancer, birth defects, and other reproductive harm. www.p65warnings.ca.gov

- 5) Replace bearing (**Fig. 5**). Place new bearing over lip seal for installation.

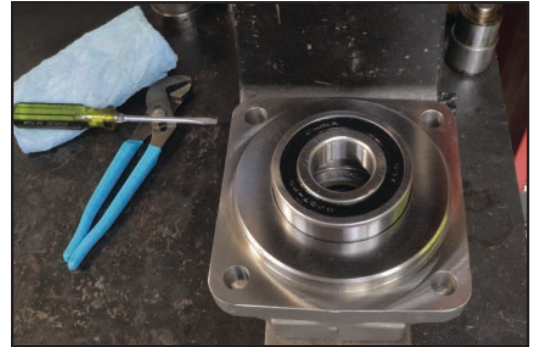

Figure 5

- 6) Press new bearing over lip seal (**Fig. 6 & 7**). Using arbor press, seat new bearing flush with lip seal.



Figure 6



Figure 7

 **WARNING:** This product can expose you to chemicals including lead or DEHP which are known to the state of California to cause cancer, birth defects, and other reproductive harm. www.p65warnings.ca.gov

- 7) Assemble the snap ring (**Fig. 8 & 9**). Using snap ring pliers, seat new snap ring on top of bearing and lip seal.



Figure 8



Figure 9

- 8) Mount shaft end cover facing down in a vise (**Fig. 10**).



Figure 10

- 9) Re-affix or replace section seal (**Fig. 11**).
Verify both sides of the section seal are free of debris. If need to replace, grease the new section seal and insert firmly into the grooves in both sides of the gear housing.



Figure 11

 **WARNING:** This product can expose you to chemicals including lead or DEHP which are known to the state of California to cause cancer, birth defects, and other reproductive harm. www.p65warnings.ca.gov

10) Assemble new sealing parts in pressure plate and verify orientation.

The sealing parts can be fixed with grease. (see below for steps to install sealing parts correctly)

- i. Turn the pressure plates so the seal groove faces up
- ii. Place the soft black into the seal groove with the flat side down
- iii. Place the hard nylon back-up seal, flat side up, into the groove on top of the rubber seal

Pump Thrust Block - Back Side (**Fig. 12a, 12b**)

Pump Thrust Block - Front Side (**Fig. 12c**)

Motor Thrust Block - Back Side (**Fig. 12d, 12e**)

Motor Thrust Block - Front Side (**Fig. 12f**)



Figure 12



Figure 12a
Pump Thrust Block - Back Side



Figure 12b
Pump Thrust Block - Back Side



Figure 12c
Pump Thrust Block - Front Side



Figure 12d
Motor Thrust Block - Back Side



Figure 12e
Motor Thrust Block - Back Side



Figure 12f
Motor Thrust Block - Front Side

The proper seal installation is very important. If these seals are assembled upside down, they will most likely fail in a short period of time under system pressure.

WARNING: This product can expose you to chemicals including lead or DEHP which are known to the state of California to cause cancer, birth defects, and other reproductive harm. www.p65warnings.ca.gov

- 11) Assemble the lower thrust block into the motor body (**Fig. 13**), using grease if needed on sealing parts.

Orientation is rotation sensitive for pumps and the seals should be pointed down and facing the high pressure side of the pump, the pressure port. Push down until the thrust block is flush with the shaft end.



Figure 13

- 12) Insert drive gear (**Fig. 14**).

Insert shaft fully until seated firmly at the bottom of port end cover.

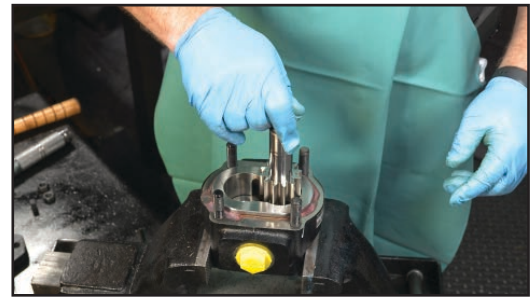

Figure 14

- 13) Insert idler gear (**Fig. 15**).

Gently turn gears until have lined up the match marks.

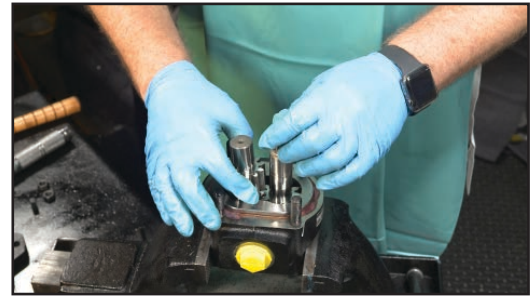



Figure 15

- 14) Insert upper thrust plate on top of gear set (**Fig. 16**).

The plate should be flush with motor body. Position is rotation sensitive.



Figure 16

 **WARNING:** This product can expose you to chemicals including lead or DEHP which are known to the state of California to cause cancer, birth defects, and other reproductive harm. www.p65warnings.ca.gov

- 15)** Slide a lubricated steel shaft seal sleeve over the drive gear (**Fig. 17**).
This will protect the gear while installing the shaft end cover.



Figure 17

- 16)** Verify section seal is free of debris and firmly on bottom of shaft end cover. Fit the shaft end cover careful from the top down to the body (**Fig. 18**).
Make sure the interlocking track is on correctly and line up match marks.

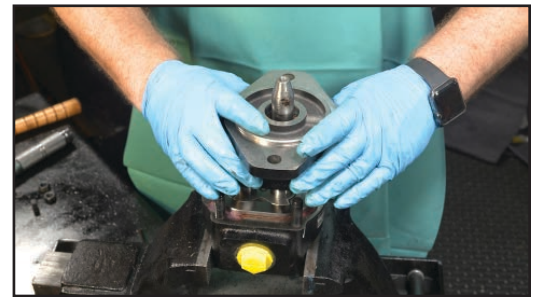

Figure 18

- 17)** Thread the fasteners onto the body and tighten alternately or in an X pattern (**Fig. 19**).
To correctly insert the back nuts and washers, hold the shaft end cover up slightly until nuts can be hand tightened. Then push body down firmly to tighten front screws.



Figure 19

- 18)** Tighten nuts (**Fig. 20**).
Begin hand tightening nuts in cross pattern, then finish with wrench. Torque diagonally opposed fasteners to correct torque.



Figure 20

 **WARNING:** This product can expose you to chemicals including lead or DEHP which are known to the state of California to cause cancer, birth defects, and other reproductive harm. www.p65warnings.ca.gov

- 19) Torque diagonally opposed fasteners to correct torque. (Fig. 21).
Do not lubricate fastener threads before assembly.
Follow torque guide below.

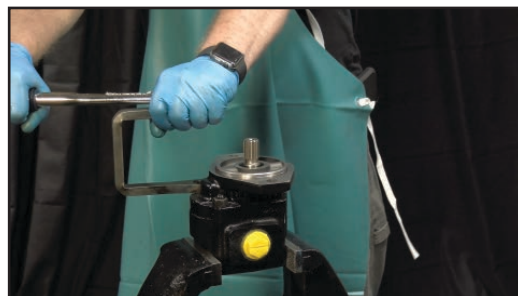



Figure 21

600 Series Torque Guide	
Series	Lbs-ft
PGP610/PGM610	43
PGP620/PGM620	70
PGP625/PGM625	70
PGP640/PGM640	103

 **WARNING:** This product can expose you to chemicals including lead or DEHP which are known to the state of California to cause cancer, birth defects, and other reproductive harm. www.p65warnings.ca.gov

Gear Housing

Wear in excess of .005" cut-out necessitates replacement of the gear housing body. Place a straight-edge across bore. If you can slip a .005" feeler gauge under the straight-edge in the cut-out area, replace the gear housing body.

Pressure pushes the gears against the housing on the low pressure side. As the hubs and bushings wear, the cut-out becomes more pronounced. Excessive cut-out in a short period of time indicates excessive pressure or oil contamination. If the relief valve settings are within prescribed limits, check for shock pressures or tampering. When the cut-out is moderate, .005" or less, the gear housing body is in good condition and may be reused.

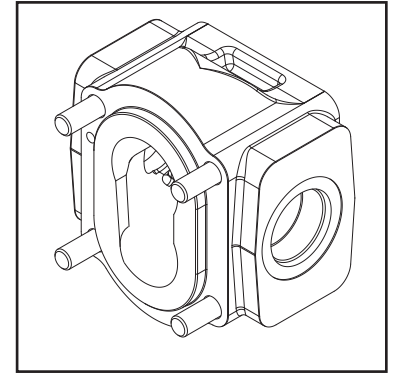
**Gears**

Any scoring on gear hubs necessitates replacement. Scoring, grooving, or burring of the outside diameter of the teeth requires replacement. Nicking, grooving, or fretting of teeth surfaces also necessitates replacement.

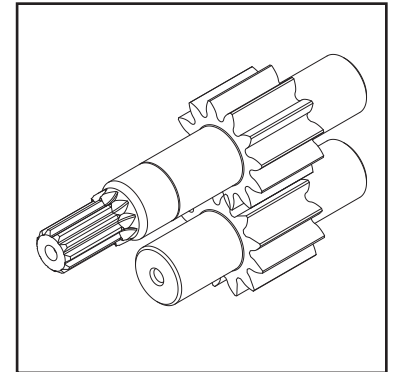
**Drive Shafts**

Replace if there is any wear detectable by touch in the seal area or at the drive coupling. The maximum allowable wear is .002". Wear in the shaft seal area indicates oil contamination. Wear or damage to splines, keys, or keyways necessitates replacement.

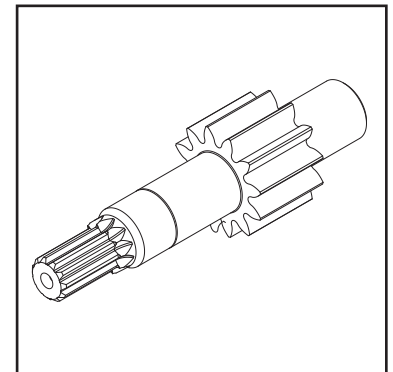
**Balance Plates**

The balance plates seal the gear section at the sides of the gears. Wear here will allow internal slippage, that is, oil will bypass within the pump.

A maximum of .002" wear is allowable. Replace balance plates if they are scored, eroded or pitted. Check center of thrust plates where the gears mesh. Erosion here indicates oil contamination.

Pitted balance plates indicate cavitation or oil aeration. Discolored balance plates indicate overheating, likely due to insufficient oil.

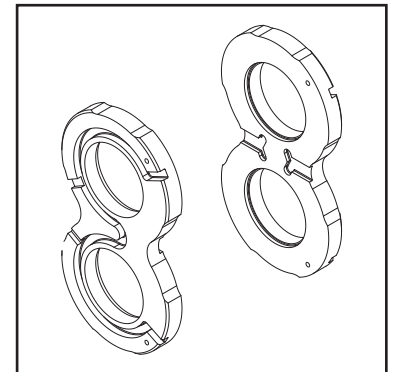

WARNING: This product can expose you to chemicals including lead or DEHP which are known to the state of California to cause cancer, birth defects, and other reproductive harm. www.p65warnings.ca.gov

Bushings

Bushings must be replaced if PTFE coating is worn through or if scored or blackened. Bushings should fit into the bore with a heavy press fit



Seals and Gaskets

Replace all rubber and polymer seals, including all o-rings, thrust plate channel seals, shaft seal and gasket seals.



Checks

Examine the checks, if unit has them, in the mounting flange to make sure that they are tight, and free of contamination.

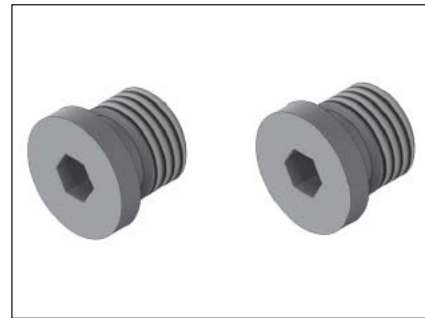

 **WARNING:** This product can expose you to chemicals including lead or DEHP which are known to the state of California to cause cancer, birth defects, and other reproductive harm. www.p65warnings.ca.gov

Hydraulic Oil Recommendations

When choosing your Hydraulic Oil, duty cycle and oil temperature must be factored in to optimize your system performance since hydraulic systems often work under extreme temperature changes, especially in moderate to severe duty cycles, the lubrication qualities of the oil in tight tolerance components is even more critical.

Viscosity choice is always a compromise; the fluid must be thin enough to flow easily but thick enough to seal and maintain a lubricating film between bearing and sealing surfaces. This film of oil helps to reduce friction and heat, which can ultimately lead to component damage.

Fluid temperature does affect viscosity. When choosing a fluid, it is important to consider the start-up and operating temperatures of the hydraulic system. In general, as the fluid warms, it gets thinner and its viscosity decreases. At the highest temperatures, the fluid must be thick enough to provide lubrication and minimize internal leakage. Low viscosity leads to the following problems:

- Higher leakage across all sealing gaps in the pump leading to lower volumetric efficiencies and heat.
- Heat will cause loss of lubrication and will create severe wear because of metal to metal contact, causing premature failure of the gears, thrust plates and bearings.

The opposite is true when the fluid cools, its viscosity increases. At the lowest temperatures, the fluid must be thin enough to flow readily. High viscosity oil leads to the following problems:

- Sealing and lubrication gaps not being filled, loss of lubrication
- Filling losses occur which causes cavitation damage to the pump

Under normal operating temperatures it is recommended to keep the temperature of the hydraulic fluid in the range of 120°F to 140°F (49°C to 60°C). Fluids may break down or oxidize at high temperatures, which leads to varnish or sludge deposits in the system and also reduces lubricity and results in reduced life of the unit. As a rule of thumb, operating temperatures over 176°F (80°C) reduce the service life by half for every 50°F (10°C) temperature increase, and should be avoided.

Petroleum Oils (Mineral-based)

Viscosity Recommendations

Optimum operating viscosity is considered to be about 100 SUS (20 cSt).

Minimum approximately: 50 - 60 SUS (7.5 - 10 cSt)

Maximum at start up approximately: 7500 SUS (1600 cSt)

Recommended Viscosity Grades:

Grade	Viscosity at 100°F (40°C)	Viscosity at 210°F (100°C)
ISO 32	165 SUS (32 cSt)	44 SUS (5 cSt)
ISO 46	240 SUS (46 cSt)	49 SUS (7 cSt)
SAE 10	150 SUS (32 cSt)	41 SUS (4 cSt)
SAE 20	300 SUS (71 cSt)	51 SUS (7 cSt)

Other Desirable Properties	Additives Usually Recommended:
Viscosity Index: 90 minimum	Rust and Oxidation (R & O) Inhibitors
Aniline Point: 175 minimum	Foam Depressant

NOTE: Antiwear (AW) additives are not necessarily recommended. In some instances the presence of zinc compounds can actually be harmful to copper, bronze, or brass components used in the system. The use of AW oil is optional with our gear units.

General Recommendations

High quality hydraulic oils are essential for satisfactory performance and long life of any hydraulic system. Such oils are usually prepared from highly refined, turbine oil stocks with which select additives are compounded. We suggest following the manufacturer's specifications or the recommendations of a reputable oil supplier for the specific oil requirements on your machine.

A high viscosity oil will generally give better performance and life than a thin oil. Oil of around 100 SUS (20 cSt) will give optimum performance. Your selection should be as near to optimum as possible at operating temperature but not so heavy at start-up as to cause cavitation. Cold start-up procedures which allow the use of heavier oils should prove worthwhile by increasing pump life. The oil must be clean and contain less than 0.1% water.

 **WARNING:** This product can expose you to chemicals including lead or DEHP which are known to the state of California to cause cancer, birth defects, and other reproductive harm. www.p65warnings.ca.gov



Hydraulic Oil Recommendations (Continued)

Petroleum Oils (Mineral-based) (Continued)

Operating Temperature

The optimum oil operating temperature is in the range of 120°-140°F (49°-60°C). Oil operating temperature should not exceed 200°F (93°C) with a maximum of 180°F (82°C) generally recommended. If the oil temperature will be above 180°F (82°C) for significant periods of time, then Viton (FKM) seals should be used. High temperatures may result in rapid oil deterioration and may point out the need for an oil cooler or a larger reservoir. The nearer to optimum temperature, the longer the service life will be of the oil, pump and other components.

Cold Weather Operation

Oils for use in cold weather should have a viscosity not exceeding 7500 SUS (1620 cSt) at the minimum start-up temperature and a pour point of at least 20°F (0° C) below that temperature. Experience on the Alaskan North Slope has been satisfactory without using special oils or fluids. Start-up procedures must allow for a gradual warm-up and equipment should not be operated at full pressure until the oil reaches a reasonably fluid state.

Inlet Vacuum

Vacuum measured at the inlet port of the pump generally should not exceed 5 in. (13 cm) Hg. Higher vacuum can result in cavitation which may severely damage the pump. A usually acceptable rule of thumb is that the inlet line velocity should not exceed 8 fps (2.5 m/s). A long inlet line or the use of several fittings may necessitate increasing the line size. We suggest that each inlet port of a tandem pump have its own line from the reservoir.

Reservoir

Reservoir capacity in gallons should at least equal total pump output in GPM. When filling the reservoir, oil should pass through a 100-mesh screen. Pour only clean oil from clean containers into the reservoir. The reservoir should have a breather to allow air in or out. The filler cap and breather should be sealed to prevent moisture from entering. A hydraulic oil water content of as little as 0.1% can cause damage to hydraulic components.

Filtration

Good filtration assures improved service life at today's high operating pressures. System filtration is recommended that will maintain a contamination level according to ISO 4406:

ISO 4406	psi	bar
21/19/16	2000	140
19/17/14	3000	210
17/15/12	4000	275

The specific filter recommendation should come from your equipment manufacturer or filter supplier.

A 100 mesh screen should generally be used in the suction line leading to the pump. It should be of sufficient size to handle twice the pump capacity. The screen must be cleaned and checked regularly to avoid pump and system damage.

Oil and filters should be changed on a regular schedule and the system flushed in accordance with the original equipment manufacturer's recommendations. Reservoir air breather filters should be cleaned periodically.

Filtration is not a substitute for practicing cleanliness and proper preventive maintenance.

 **WARNING:** This product can expose you to chemicals including lead or DEHP which are known to the state of California to cause cancer, birth defects, and other reproductive harm. www.p65warnings.ca.gov



Hydraulic Oil Recommendations (Continued)

Water Base Fire Resistant Fluids

Two types of water base fluids (WBF) may be used with our gear pumps and motors. Both types of WBF come in various viscosity grades. Select the grade best suited to the equipment and its operation in terms of pressure, speed, temperature, duty cycle, etc. The fluid used should be recommended by the O.E.M. or a reputable fluid supplier.

Operations outside the range of 400 to 2000 rpm and over 3000 psi (2000/2500 psi in the wider gear widths) should be reviewed with your Parker sales representative.

Water-in Oil (60/40) invert Emulsions

Invert emulsions are approved for use with our bushing style pumps at pressures up to 3000 psi or 500 psi below catalog rated pressures, whichever is lower.

With roller bearing pumps, life may be reduced to 20% to 50% of that experienced with petroleum oil. Reducing the pressure and/or gear width can extend pump life appreciably.

Water Glycol Solutions

Water glycol solutions of the types normally used in hydrostatic systems are recommended for use with our bushing style pumps. These consist of about 60% glycol and about 40% water with additives to improve lubricity and other characteristics. Pressures up to 3000 psi are approved, depending on the gear width. Water glycol solutions are not approved for use with our roller bearing pumps.

WBF Filtration

Filtration that seems to give the best results consists of a 100-mesh inlet screen and a return line filter. For water base fluids, the inlet screen should be sized up three to four times the pump capacity. The return line filter should be of a rating and size recommended by the fluid and filter manufacturers to achieve a recommended ISO contamination level.

NOTE: Finer filtration may be required by other components in the system.

High Water Base Fluids (HWBF)

The use of 95/5 emulsion is not recommended.

Phosphate Ester

Phosphate ester does not appear to affect pump performance and service life, but Viton (FKM) seals should be used with this fluid. Viscosity characteristics of phosphate ester fluid limit the recommended ranges of operating and ambient temperatures. Questions on the use of fluids with our equipment should be discussed with a sales representative or Product Support Dept

Comments: Use of other oils and fluids

Biodegradable Oil (Vegetable-Based)

Oils of this type with properties similar to recommended petroleum oils may be used with our bushing style pumps only. These are not approved for use in our roller bearing pumps. Performance, pressure ratings and durability are not adversely affected in bushing style pumps.

Automatic Transmission Fluid (ATF)

In general, these oils have low viscosity and may be used only at reduced operating pressures and oil temperatures.

Diesel Fuel, Kerosene, Coal Oil

Although sometimes used as a dilutant for cold weather operations, their use is not recommended because they are insufficiently refined products.

Transformer Oil

Sometimes used for extremely cold weather operation. It is not generally recommended as it becomes too thin at normal operating temperatures. Oil to U.S. Military Spec MIL-H-5606 is in this category.

Operating Limits Generally Recommended with Various Fluids

Fluid	Max. Operating Temp.	Max. Inlet Line Velocity	Max. Inlet Vacuum
Petroleum Oil	180°F (82°C)	8 fps (2.5m/s)	5" (13cm) Hg
WIO Emulsion	150°F (65°C)	4 fps (1.2m/s)	0" (0cm) Hg
Water Glycol	150°F (65°C)	4 fps (1.2m/s)	0" (0cm) Hg

NOTE: These figures represent generally accepted maximums and will not prove satisfactory in all installations. For very severe duty cycles, it will likely be advantageous to design and operate the system at something less than these maximum limits.

- DO NOT USE ANY TYPE OF FLUID NOT RECOMMENDED IN THIS BULLETIN WITHOUT FIRST CONSULTING OUR PRODUCT SUPPORT DEPT
- OBTAIN YOUR FINAL FLUID RECOMMENDATION FROM YOUR FLUID SUPPLIER

 **WARNING:** This product can expose you to chemicals including lead or DEHP which are known to the state of California to cause cancer, birth defects, and other reproductive harm. www.p65warnings.ca.gov



Recommended Start-up Procedure for New or Rebuilt Pump

Before installing a new or rebuilt pump, back off the main relief valve until the spring tension on the adjusting screw is relieved. This will avoid the possibility of immediate damage to the replacement unit in the event that the relief valve setting had been increased beyond the recommended operating pressure, prior to removing the old unit.

Before connecting any lines to the pump, fill all ports with clean oil to provide initial lubrication. This is particularly important if the unit is located above the oil reservoir.

After connecting the lines and mounting the replacement unit, operate the pump at least two minutes at no load and at low rpm (400 min.) During this break-in period, the unit should run free and not develop an excessive amount of heat. If the unit operates properly, speed and pressure can then be increased to normal operating settings.

Reset the main relief valve to its proper setting while the pump is running at maximum operating engine (motor) speed for the vehicle.

ALWAYS USE AN ACCURATE GAUGE WHEN ADJUSTING THE RELIEF VALVE PRESSURE SETTING.

Recommended Test Procedure

Make certain that there is an adequate supply of oil for the pump; at least one gallon of oil for each gpm of pump capacity.

If one section of a tandem pump is being tested, make sure that all other sections not being tested are adequately supplied with oil. If any of the other sections run dry, or if plugs are left in ports, serious and permanent damage will result.

The oil should be a good quality hydraulic oil rated at 150 SSU at 100°F, with the oil temperature held at 120°F plus or minus 50°F. (Test procedures are described in detail in SAE handbooks; see Hydraulic Power Pump Test Procedure, SAE J745c.)

The feed line must be of adequate size with no more than 5" mercury vacuum adjacent to the pump inlet. As a rule, the feed line must provide a feed flow velocity not in excess of 8 feet per second.

Feeding hot oil into a cold pump may cause the pump to seize. Jog the pump by momentarily starting and stopping repeatedly the driving engine or motor to gradually equalize pump and oil temperatures.

Run the pump at least two minutes at no load and moderate speed (not over 1500 rpm). If the pump becomes excessively hot, shut down immediately and locate the problem source.

Gradually increase pressure on pump, in 500 psi increments

until the desired test pressure has been reached. This should take about five minutes.

Delivery should run close to rated catalog performance figures, which are averaged from testing several pumps. A 5% lower reading may be used as a rated minimum if new or relatively new parts have been used. When rebuilding the pump with parts from the original pump, which, while worn, appear satisfactory for reuse, a 10% or 15% lower reading may be permitted, depending on the performance expected from the equipment. One's own experience will prove the best guide here.

Many repairmen measure the output at normal operating speed and at zero pressure, then again at 1000 psi (or the operating pressure of the equipment) and allow a volume decrease approximating the listing below. It is a suggested reference only which makes allowance for reused parts.

At test speeds other than 1800 rpm, gpm delivery will vary almost proportionately, but the same (drop-off) figures should be used.

Be sure to run the pump in the direction for which it was designed and built. Driving the pump in the wrong direction will build up pressure behind the shaft seal, damaging it and necessitating replacement.

After completing testing procedures, the pump is ready for installation and immediate duty operation on equipment. Again, it must be remembered that to prevent seizure, hot oil must not be fed into a cold pump.

GPM DELIVERY at 1800 rpm 100 psi	GPM DROP OFF AT...		
	1000 psi/70 bar	2000 psi/140 bar	3000 psi/210 bar
10-30	1-1/2 - 3	2 - 3-1/2	2-1/2 - 4
30-50	2 - 3	2-1/2 - 4	3 - 4-1/2
50-70	2-1/2 - 3-1/2	3-5	3-1/2 - 5-1/2

 **WARNING:** This product can expose you to chemicals including lead or DEHP which are known to the state of California to cause cancer, birth defects, and other reproductive harm. www.p65warnings.ca.gov



PARKER-HANNIFIN CORPORATION
OFFER OF SALE

1. Definitions. As used herein, the following terms have the meanings indicated.

"Buyer" means any customer receiving a Quote for Products.

"Buyer's Property" means any tools, patterns, plans, drawings, designs, specifications materials, equipment, or information furnished by Buyer, or which are or become Buyer's property.

"Confidential Information" means any technical, commercial, or other proprietary information of Seller, including, without limitation, pricing, technical drawings or prints and/or part lists, which has been or will be disclosed, delivered, or made available, whether directly or indirectly, to Buyer.

"Goods" means any tangible part, system or component to be supplied by Seller.

"Intellectual Property Rights" means any patents, trademarks, copyrights, trade dress, trade secrets or similar rights.

"Products" means the Goods, Services and/or Software as described in a Quote.

"Quote" means the offer or proposal made by Seller to Buyer for the supply of Products.

"Seller" means Parker-Hannifin Corporation, including all divisions, subsidiaries and businesses selling Products under these Terms.

"Seller's IP" means patents, trademarks, copyrights, or other intellectual property rights relating to the Products, including without limitation, names, designs, images, drawings, models, software, templates, information, any improvements or creations or other intellectual property developed prior to or during the relationship contemplated herein.

"Services" means any services to be provided by Seller.

"Software" means any software related to the Goods, whether embedded or separately downloaded.

"Special Tooling" means equipment acquired by Seller or otherwise owned by Seller necessary to manufacture Goods, including but not limited to tools, jigs, and fixtures.

"Terms" means the terms and conditions of this Offer of Sale.

2. Terms. All sales of Products by Seller will be governed by, and are expressly conditioned upon Buyer's assent to, these Terms. These Terms are incorporated into any Quote provided by Seller to Buyer. Buyer's order for any Products whether communicated to Seller verbally, in writing, by electronic data interface or other electronic commerce, shall constitute acceptance of these Terms. Seller objects to any contrary or additional terms or conditions of Buyer. Reference in Seller's order acknowledgement to Buyer's purchase order or purchase order number shall in no way constitute an acceptance of any of Buyer's terms or conditions of purchase. Any Quote made by Seller to Buyer shall be considered a firm and definite offer and shall not be deemed to be otherwise despite any language on the face of the Quote. Seller reserves all rights to accept or reject any purported acceptance by Buyer to Seller's Quote if such purported acceptance attempts to vary the terms of the Quote. If Seller ships Products after Buyer issues an acceptance to the Quote, any additional or different terms proposed by Buyer will not become part of the parties' business relationship unless agreed to in a writing that is signed by an authorized representative of Seller, excluding email correspondence. If the transaction proceeds without such agreement on the part of Seller, the business relationship will be governed solely by these Terms and the specific terms in Seller's Quote.

3. Price; Payment. The Products set forth in the Quote are offered for sale at the prices indicated in the Quote. Unless otherwise specifically stated in the Quote, prices are valid for thirty (30) days and do not include any sales, use, or other taxes or duties. Seller reserves the right to modify prices for any reason and at any time by giving ten (10) days prior written notice. Unless otherwise specified by Seller, all prices are F.C.A. Seller's facility (INCOTERMS 2020). All sales are contingent upon credit approval and full payment for all purchases is due thirty (30) days from the date of invoice (or such date as may be specified in the Quote). Under any circumstances, Buyer may not withhold or suspend payment of any amounts due and payable as a deduction, set-off or recoupment of any amount, claim or dispute with Seller. Unpaid invoices beyond the specified payment date incur interest at the rate of 1.5% per month or the maximum allowable rate under applicable law. Seller reserves the right to require advance payment or provision of securities for first and subsequent deliveries if there is any doubt, in Seller's sole determination, regarding the Buyer's creditworthiness or for other business reasons. If the requested advance payment or securities are not provided to Seller's satisfaction, Seller reserves the right to suspend performance or reject the purchase order, in whole or in part, without prejudice to Seller's other rights or remedies, including the right to full compensation. Seller may revoke or shorten any payment periods previously granted in Seller's sole determination. The rights and remedies herein reserved to Seller are cumulative and in

addition to any other or further rights and remedies available at law or in equity. No waiver by Seller of any breach by Buyer of any provision of these terms will constitute a waiver by Seller of any other breach of such provision.

4. Shipment; Delivery; Title and Risk of Loss. All delivery dates are approximate, and Seller is not responsible for damages or additional costs resulting from any delay. All deliveries are subject to our ability to procure materials from our suppliers. Regardless of the manner of shipment, delivery occurs and title and risk of loss or damage pass to Buyer, upon placement of the Products with the carrier at Seller's facility. Unless otherwise agreed prior to shipment and for domestic delivery locations only, Seller will select and arrange, at Buyer's sole expense, the carrier and means of delivery. When Seller selects and arranges the carrier and means of delivery, freight and insurance costs for shipment to the designated delivery location will be prepaid by Seller and added as a separate line item to the invoice. Buyer shall be responsible for any additional shipping charges incurred by Seller due to Buyer's acts or omissions. Buyer shall not return or repackage any Products without the prior written authorization from Seller, and any return shall be at the sole cost and expense of Buyer.

5. Warranty. The warranty for the Products is as follows:

(i) Goods are warranted against defects in material or workmanship for a period of twelve (12) months from the date of delivery or 2,000 hours of use, whichever occurs first; (ii) Services shall be performed in accordance with generally accepted practices and using the degree of care and skill that is ordinarily exercised and customary in the field to which the Services pertain and are warranted for a period of six (6) months from the date of completion of the Services; and (iii) Software is only warranted to perform in accordance with applicable specifications provided by Seller to Buyer for ninety (90) days from the date of delivery or, when downloaded by a Buyer or end-user, from the date of the initial download. All prices are based upon the exclusive limited warranty stated above, and upon the following disclaimer: **EXEMPTION CLAUSE; DISCLAIMER OF WARRANTY, CONDITIONS, REPRESENTATIONS: THIS WARRANTY IS THE SOLE AND ENTIRE WARRANTY, CONDITION, AND REPRESENTATION, PERTAINING TO PRODUCTS. SELLER DISCLAIMS ALL OTHER WARRANTIES, CONDITIONS, AND REPRESENTATIONS, WHETHER STATUTORY, EXPRESS OR IMPLIED, INCLUDING BUT NOT LIMITED TO THOSE RELATING TO DESIGN, NONINFRINGEMENT, MERCHANTABILITY, AND FITNESS FOR A PARTICULAR PURPOSE. SELLER DOES NOT WARRANT THAT THE SOFTWARE IS ERROR-FREE OR FAULT-TOLERANT, OR THAT BUYER'S USE THEREOF WILL BE SECURE OR UNINTERRUPTED, UNLESS OTHERWISE AUTHORIZED IN WRITING BY SELLER, THE SOFTWARE SHALL NOT BE USED IN CONNECTION WITH HAZARDOUS OR HIGH-RISK ACTIVITIES OR ENVIRONMENTS. EXCEPT AS EXPRESSLY STATED HEREIN, ALL PRODUCTS ARE PROVIDED "AS IS"**.

6. Claims; Commencement of Actions. Buyer shall promptly inspect all Products upon receipt. No claims for shortages will be allowed unless reported to Seller within ten (10) days of delivery. Buyer shall notify Seller of any alleged breach of warranty within thirty (30) days after the date the non-conformance is or should have been discovered by Buyer. Any claim or action against Seller based upon breach of contract or any other theory, including tort, negligence, or otherwise must be commenced within twelve (12) months from the date of the alleged breach or other alleged event, without regard to the date of discovery.

7. LIMITATION OF LIABILITY. IN THE EVENT OF A BREACH OF WARRANTY, SELLER WILL, AT ITS OPTION, REPAIR OR REPLACE THE NON-CONFORMING PRODUCTS, RE-PERFORM THE SERVICES, OR REFUND THE PURCHASE PRICE PAID WITHIN A REASONABLE PERIOD OF TIME. IN NO EVENT IS SELLER LIABLE FOR ANY SPECIAL, INDIRECT, INCIDENTAL OR CONSEQUENTIAL DAMAGES INCLUDING ANY LOSS OF REVENUE OR PROFITS, WHETHER BASED IN CONTRACT, TORT OR OTHER LEGAL THEORY. IN NO EVENT SHALL SELLER'S LIABILITY UNDER ANY CLAIM MADE BY BUYER EXCEED THE PURCHASE PRICE PAID FOR THE PRODUCTS.

8. Confidential Information. Buyer acknowledges and agrees that Confidential Information has been and will be received in confidence and will remain the property of Seller. Buyer further agrees that it will not use Seller's Confidential Information for any purpose other than for the benefit of Seller and shall return all such Confidential Information to Seller within thirty (30) days upon request.

9. Loss to Buyer's Property. Buyer's Property will be considered obsolete and may be destroyed by Seller after two (2) consecutive years have elapsed without Buyer ordering the Products manufactured using Buyer's Property.

Also, Seller shall not be responsible for any loss or damage to Buyer's Property while it is in Seller's possession or control.

10. Special Tooling. Seller may impose a tooling charge for any Special Tooling. Special Tooling shall be and remain Seller's property. In no event will Buyer acquire any interest in the Special Tooling, even if such Special Tooling has been specially converted or adapted for manufacture of Goods for Buyer and notwithstanding any charges paid by Buyer. Unless otherwise agreed, Seller has the right to alter, discard or otherwise dispose of any Special Tooling or other property owned by Seller in its sole determination at any time.

11. Security Interest. To secure payment of all sums due from Buyer, Seller retains a security interest in all Products delivered to Buyer and, Buyer's acceptance of these Terms is deemed to be a Security Agreement under the Uniform Commercial Code. Buyer authorizes Seller as its attorney to execute and file on Buyer's behalf all documents Seller deems necessary to perfect Seller's security interest.

12. User Responsibility. Buyer, through its own analysis and testing, is solely responsible for making the final selection of the Products and assuring that all performance, endurance, maintenance, safety and warning requirements of the application of the Products are met. Buyer must analyze all aspects of the application and follow applicable industry standards, specifications, and any technical information provided with the Quote or the Products, such as Seller's instructions, guides and specifications. If Seller provides options of or for Products based upon data or specifications provided by Buyer, Buyer is responsible for determining that such data and specifications are suitable and sufficient for all applications and reasonably foreseeable uses of the Products. In the event Buyer is not the end-user of the Products, Buyer will ensure such end-user complies with this paragraph.

13. Use of Products, Indemnity by Buyer. Buyer shall comply with all instructions, guides and specifications provided by Seller with the Quote or the Products. If Buyer uses or resells the Products in any way prohibited by Seller's instructions, guides or specifications, or Buyer otherwise fails to comply with Seller's instructions, guides and specifications, Buyer acknowledges that any such use, resale, or non-compliance is at Buyer's sole risk. Further, Buyer shall indemnify, defend, and hold Seller harmless from any losses, claims, liabilities, damages, lawsuits, judgments and costs (including attorney fees and defense costs), whether for personal injury, property damage, intellectual property infringement or any other claim, arising out of or in connection with: (a) improper selection, design, specification, application, or any misuse of Products; (b) any act or omission, negligent or otherwise, of Buyer; (c) Seller's use of Buyer's Property; (d) damage to the Products from an external cause, repair or attempted repair by anyone other than Seller, failure to follow instructions, guides and specifications provided by Seller, use with goods not provided by Seller, or opening, modifying, deconstructing, tampering with or repackaging the Products; or (e) Buyer's failure to comply with these Terms, including any legal or administrative proceedings, collection efforts, or other actions arising from or relating to such failure to comply. Seller shall not indemnify Buyer under any circumstance except as otherwise provided in these Terms.

14. Cancellations and Changes. Buyer may not cancel or modify, including but not limited to movement of delivery dates for the Products, any order for any reason except with Seller's written consent and upon terms that will indemnify, defend and hold Seller harmless against all direct, incidental and consequential loss or damage and any additional expense. Seller, at any time, may change features, specifications, designs and availability of Products.

15. Assignment. Buyer may not assign its rights or obligations without the prior written consent of Seller.

16. Force Majeure. Seller is not liable for delay or failure to perform any of its obligations by reason of any events or circumstances beyond its reasonable control. Such circumstances include without limitation: accidents, labor disputes or stoppages, government acts or orders, acts of nature, pandemics, epidemics, other widespread illness, or public health emergency, cyber related disruptions, cyber-attacks, ransomware sabotage, delays or failures in delivery from carriers or suppliers, shortages of materials, sudden increases in the price of raw material or components, shutdowns or slowdowns affecting the supply of raw materials or components, or the transportation thereof, oil shortages or oil price increases, energy crisis, energy or fuel interruption, war (whether declared or not) or the serious threat of same, riots, rebellions, acts of terrorism, embargoes, fire or any reason whether similar to the foregoing or otherwise. Seller will resume performance as soon as practicable after the event of force majeure has been removed. All delivery dates affected by an event of force majeure shall be tolled for the duration of such event of force majeure and rescheduled for mutually agreed dates as soon as practicable after the event of force majeure ceases to exist. The right to allocate capacity is in the Seller's sole discretion. An event of force majeure shall not include

financial distress, insolvency, bankruptcy, or other similar conditions affecting one of the parties, affiliates and/or subcontractors. An event of force majeure in the meaning of these Terms means any circumstances beyond Seller's control that permanently or temporarily hinders performance, even where that circumstance was already foreseen. Buyer shall not be entitled to cancel any orders following its claim of an event of force majeure.

17. Waiver and Severability. Failure to enforce any provision of these Terms will not invalidate that provision; nor will any such failure prejudice either party's right to enforce that provision in the future. Invalidation of any provision of these Terms shall not invalidate any other provision herein and, the remaining provisions will remain in full force and effect.

18. Duration. Unless otherwise stated in the Quote, any agreement governed by or arising from these Terms shall: (a) be for an initial duration of one (1) year; and (b) shall automatically renew for successive one-year terms unless terminated by Buyer with at least 180-days written notice to Seller or if Seller terminates the agreement pursuant to Section 19 of these Terms.

19. Termination. Seller may, without liability to Buyer, terminate any agreement governed by or arising from these Terms for any reason and at any time by giving Buyer thirty (30) days prior written notice. Seller may immediately terminate, in writing, if Buyer: (a) breaches any provision of these Terms, (b) becomes or is deemed insolvent, (c) appoints or has appointed a trustee, receiver or custodian for all or any part of Buyer's property, (d) files a petition for relief in bankruptcy on its own behalf, or one is filed against Buyer by a third party, (e) makes an assignment for the benefit of creditors; or (f) dissolves its business or liquidates all or a majority of its assets.

20. Ownership of Rights. Buyer agrees that (a) Seller (and/or its affiliates) owns or is the valid licensee of Seller's IP and (b) the furnishing of information, related documents or other materials by Seller to Buyer does not grant or transfer any ownership interest or license in or to Seller's IP to Buyer, unless expressly agreed in writing. Without limiting the foregoing, Seller retains ownership of all Software supplied to Buyer. In no event shall Buyer obtain any greater right in and to the Software than a right in a license limited to the use thereof and subject to compliance with any other terms provided with the Software. Buyer further agrees that it will not, directly or through intermediaries, reverse engineer, decompile, or disassemble any Software (including firmware) comprising or contained within a Product, except and only to the extent that such activity may be expressly permitted, either by applicable law or, in the case of open source software, the applicable open source license.

21. Indemnity for Infringement of Intellectual Property Rights. Seller is not liable for infringement of any Intellectual Property Rights except as provided in this Section. Seller will defend at its expense and will pay the cost of any settlement or damages awarded in an action brought against Buyer based on a third-party claim that one or more of the Products infringes the Intellectual Property Rights of a third party in the country of delivery of the Products by Seller to Buyer. Seller's obligation to defend and indemnify Buyer is contingent on Buyer notifying Seller within ten (10) days after Buyer becomes aware of any such claim, and Seller having sole control over the defense of the claim including all negotiations for settlement or compromise. If one or more Products is subject to such a claim, Seller may, at its sole expense and option, procure for Buyer the right to continue using the Products, replace or modify the Products to render them non-infringing, or offer to accept return of the Products and refund the purchase price less a reasonable allowance for depreciation. Seller has no obligation or liability for any claim of infringement: (i) arising from information provided by Buyer (including Seller's use of Buyer's Property); or (ii) directed to any Products for which the designs are specified in whole or part by Buyer; or (iii) resulting from the modification, combination or use in a system of any Products. The foregoing provisions of this Section constitute Seller's sole and exclusive liability and Buyer's sole and exclusive remedy for claims of infringement of Intellectual Property Rights.

22. Governing Law. These Terms, the terms of any Quote, and the sale and delivery of all Products are deemed to have taken place in, and shall be governed and construed in accordance with, the laws of the State of Ohio, as applicable to contracts executed and wholly performed therein and without regard to conflicts of laws principles. Buyer irrevocably agrees and consents to the exclusive jurisdiction and venue of the courts of Cuyahoga County, Ohio with respect to any dispute, controversy or claim arising out of or relating to the sale and delivery of the Products.

23. Entire Agreement. These Terms, along with the terms set forth in the Quote, forms the entire agreement between the Buyer and Seller and constitutes the final, complete and exclusive expression of the terms of sale and purchase. In the event of a conflict between any term set forth in the Quote and these Terms, the terms set forth in the Quote shall prevail. All prior or contemporaneous written or oral agreements or negotiations with

respect to the subject matter shall have no effect. No modification to these Terms will be binding on Seller unless agreed to in a writing that is signed by an authorized representative of Seller, excluding email correspondence, 'clickwrap' or other purported electronic assent to different or additional terms. Sections 2-25 of these Terms shall survive termination or cancellation of any agreement governed by or arising from these Terms.

24. No 'Wrap' Agreements/No Authority to Bind. Seller's clicking any buttons or any similar action, such as clicking "I Agree" or "Confirm," to utilize Buyer's software or webpage for the placement of orders, is NOT an agreement to Buyer's Terms and Conditions. **NO EMPLOYEE, AGENT OR REPRESENTATIVE OF SELLER HAS THE AUTHORITY TO BIND SELLER BY THE ACT OF CLICKING ANY BUTTON OR SIMILAR ACTION ON BUYER'S WEBSITE OR PORTAL.**

25. Compliance with Laws. Buyer agrees to comply with all applicable laws, regulations, and industry and professional standards, including those of the United States of America, and the country or countries in which Buyer may operate, including without limitation the U.S. Foreign Corrupt Practices Act ("FCPA"), the U.S. Anti-Kickback Act ("Anti-Kickback Act"), U.S. and E.U. export control and sanctions laws ("Export Laws"), the U.S. Food Drug and Cosmetic Act ("FDCA"), and the rules and regulations promulgated by the U.S. Food and Drug Administration ("FDA"), each as currently amended. Buyer agrees to indemnify, defend, and hold harmless Seller from the consequences of any violation of such laws, regulations and standards by Buyer, its employees or agents. Buyer represents that it is familiar with all applicable provisions of the FCPA, the Anti-Kickback Act, Export Laws, the FDCA and the FDA and certifies that Buyer will adhere to the requirements thereof and not take any action that would make Seller violate such requirements. Buyer represents and agrees that Buyer will not make any payment or give anything of value, directly or indirectly, to any governmental official, foreign political party or official thereof, candidate for foreign political office, or commercial entity or person, for any improper purpose, including the purpose of influencing such person to purchase Products or otherwise benefit the business of Seller. Buyer further represents and agrees that it will not receive, use, service, transfer or ship any Products from Seller in a manner or for a purpose that violates Export Laws or would cause Seller to be in violation of Export Laws. Buyer agrees to promptly and reliably provide Seller all requested information or documents, including end-user statements and other written assurances, concerning Buyer's ongoing compliance with Export Law.



Parker Hannifin Corporation
Pump & Motor Division
101 Canterbury Road
Kings Mountain, NC 28086
Phone: (704) 730-2000
Fax: (704) 730-7411
www.parker.com/pmd
www.phtruck.com

Your Local Authorized Parker Distributor